

ASSEMBLY INSTRUCTIONS

AUFBAUANLEITUNG

INSTRUCTIONS DE MONTAGE

ALDOCK CLICK-ADAPTER

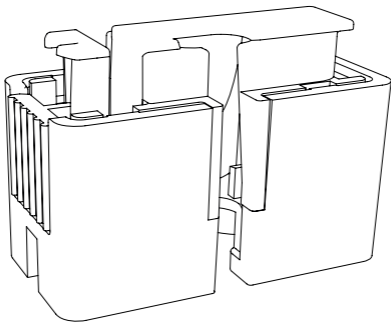

ALDOCK
DESIGNED TO CHARGE

Hello / Hallo / Bonjour

EN thank you very much for buying the ALLDOC K Click-Adapter. Please follow the instructions below.

DE Vielen Dank, das du den ALLDOCK Click-Adapter gekauft hast. Halte Dich bitte an die nachfolgenden Hinweise

FR Merci beaucoup d'avoir acheté l'Alldoc k Click-Adapter. Veuillez suivre les instructions ci-dessous.

1. Scope of delivery / Lieferumfang / Champ d'application

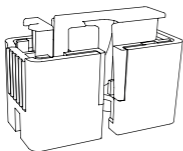

1 x Click-Adapter
1 x Click-Adapter
1 x Click-Adapteur

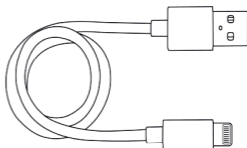

1 x Charging cable
1 x Ladekabel
1 x Câble de chargement

2. Cutting rubber inlay / Gummi Inlay schneiden / Découpe d'une incrustation en caoutchouc

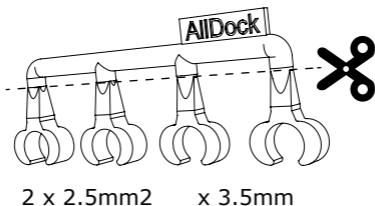

- EN** The rubber inlays are designed to adjust the height of the plugs to the respective cell phone protective case. For thicker protective cases, the larger inlays must be used.
- DE** Die Gummieinlagen sind für die Höhenanpassung der Stecker an die jeweilige Handy-Schutzhülle vorgesehen. Je dicker die Schutzhülle, desto größere Inlays müssen verwendet werden.
- FR** Les incrustations en caoutchouc permettent d'ajuster la hauteur des bouchons au couvercle de protection du téléphone portable correspondant. Plus le couvercle de protection est épais, plus les incrustations doivent être grandes.

3. Inserting rubber inlay /
Gummi Inlay einsetzen / ☒
Insérer l'insert en caoutchouc

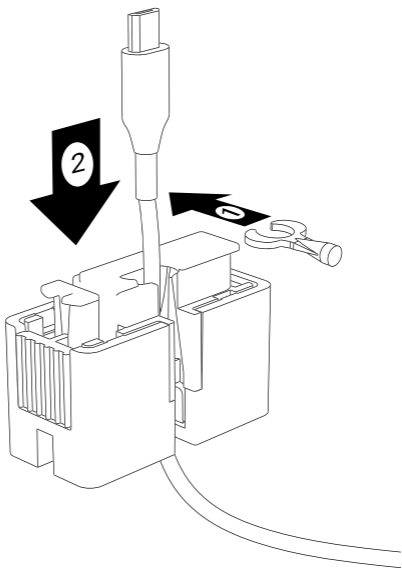

4. **Tighten cable /**
Kabel festziehen /
Resserrer le câble

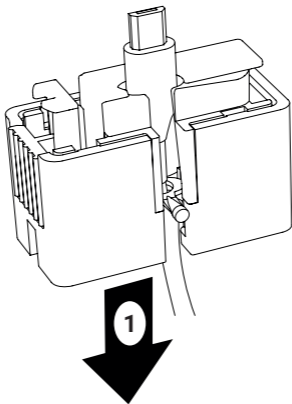

- 5. Turn Click-Adapter upside down /
Click-Adapter umdrehen /
Inverser le Click-Adaptateur**

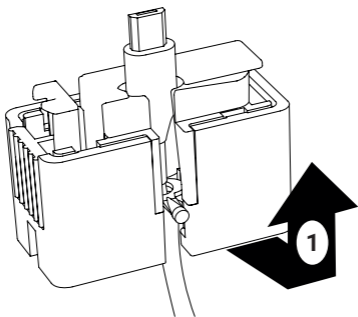

6. Fixing the cable / Kabel fixieren / Fixer le câble

- EN** Tighten the cable on the underside and wrap it around the rod. Push it strongly into the shaft with your fingertips.
- DE** Das Kabel auf der Unterseite festziehen und um den Stab wickeln. Mit den Fingerspitzen kräftig in den Schacht hineindrücken.
- FR** Serrez le câble sur la face inférieure et autour de la barre. Du bout des doigts dans le puits du bout des doigts.

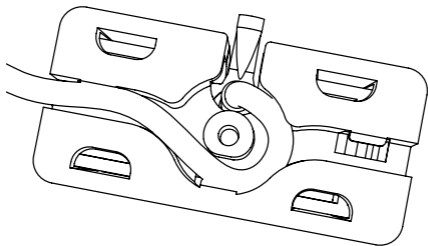

7. Click in / Einklicken / Cliquez ici

- EN** Press the Click-Adapter against the ribbed lever into the selected position and push it carefully in .
- DE** Click-Adapter gegen den geriffelten Hebel auf die gewünschte Position drücken und vorsichtig einklicken.
- FR** Cliquer l'adaptateur contre le levier rainuré à la position souhaitée et cliquez attentivement.

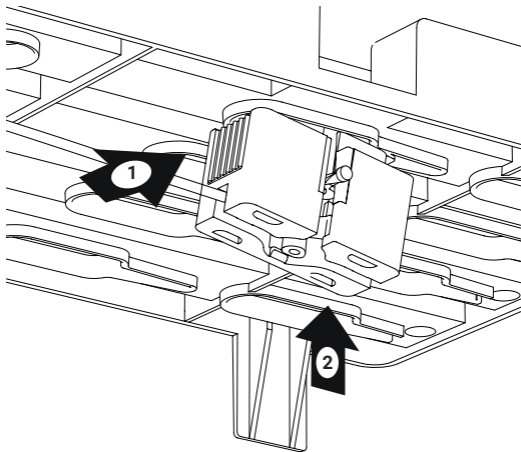

8. Connect / Verbinden / Connectez-vous à

- EN** Connect the charging cable with the ALLDOCK charger .
- DE** Ladekabel mit ALLDOCK Ladegerät verbinden .
- FR** Connectez le câble de charge au ALLDOCK chargeur .

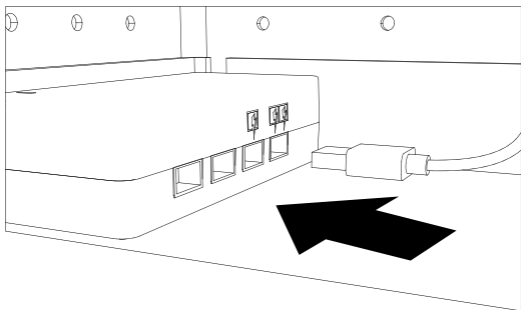

9. Close and charge / Schließen und laden / Fermer et charger

- EN** Close the top . Click-Adapter is ready to charge.
- DE** Deckel schließen . Click-Adapter ist bereit zum laden.
- FR** Fermez le couvercle. Le Click-Adapter est prêt pour le chargement .

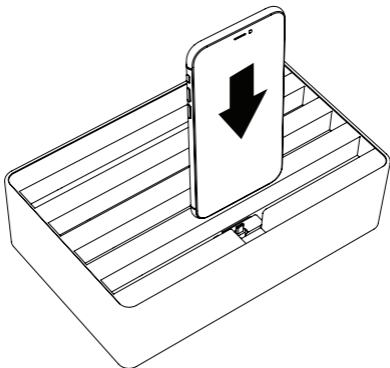

10. Change position / Position ändern / Changer de position

- EN** Press the Click-Adapter against the ribbed lever and pull it out .
- DE** Click-Adapter gegen den geriffelten Hebel drücken und herausziehen.
- FR** Appuyez le Click-Adaptateur à cliquet contre le levier rainuré et retirez-le.

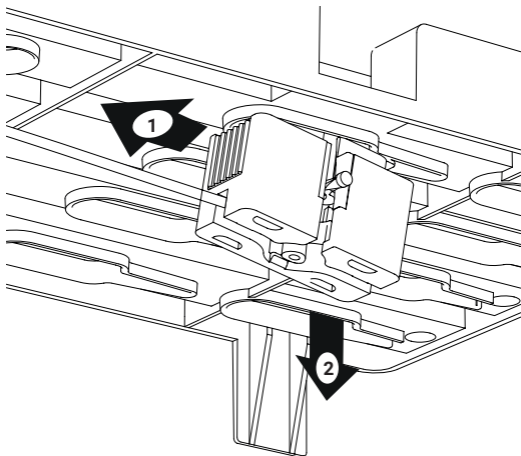

Questions? / Fragen? / Des questions?

Check out our FAQ or contact our customer care:

Prüfe unsere FAQ oder kontaktiere unseren Kundenservice:

Consultez notre FAQ ou contactez notre service clientèle:

USA and Canada:

alldock.com

Australia and New Zealand:

alldock.com.au

Europe:

alldock.eu

Germany / Deutschland:

alldock.de

ALLDOCK



HQ: Alldock GmbH, Wuppertaler Str. 80, 45549 Sprockhövel, Germany

USA: Alldock USA LLC, 1510 Fashion Island Blvd, Suite 300, San Mateo, CA 94404

Australia: Alldock Australasia Pty Ltd, 414 Lower Dandenong Rd, Braeside, VIC, 3195